

# Technical data sheet

## Product features



### Combi convection steam oven STEAMBOX electric 10x GN 2/1 automatic cleaning boiler 400 V

<b>Model</b>	<b>SAP Code</b>	00008522
--------------	-----------------	----------



- Steam type: Symbiotic - boiler and injection combination (patent)
- Number of GN / EN: 10
- GN / EN size in device: GN 2/1
- GN device depth: 65
- Control type: Touchscreen + buttons
- Display size: 9"
- Humidity control: MeteoSystem - regulation based on direct measurement of humidity in the chamber (patented)
- Advanced moisture adjustment: Steamtuner - 5-stage system of setting steam saturation by controlled combination of production by boiler or injection
- Delta T heat preparation: Yes
- Automatic preheating: Yes
- Multi level cooking: Drawer program - control of heat treatment for each dish separately
- Door constitution: Vented safety double glass, removable for easy cleaning

<b>SAP Code</b>	00008522	<b>Steam type</b>	Symbiotic - boiler and injection combination (patent)
<b>Net Width [mm]</b>	1120	<b>Number of GN / EN</b>	10
<b>Net Depth [mm]</b>	845	<b>GN / EN size in device</b>	GN 2/1
<b>Net Height [mm]</b>	1115	<b>GN device depth</b>	65
<b>Net Weight [kg]</b>	220.00	<b>Control type</b>	Touchscreen + buttons
<b>Power electric [kW]</b>	28.300	<b>Display size</b>	9"
<b>Loading</b>	400 V / 3N - 50 Hz		

# Technical data sheet

Technical drawing



Combi convection steam oven STEAMBOX electric 10x GN 2/1 automatic cleaning boiler 400 V

Model

SAP Code

00008522

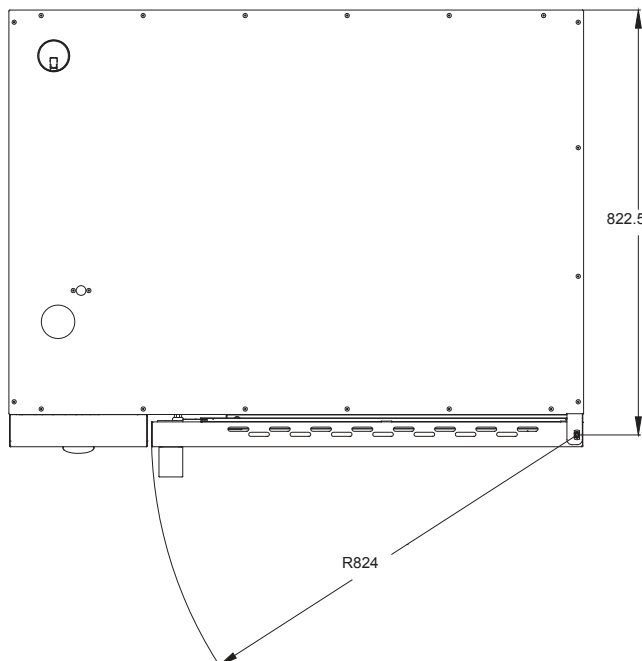
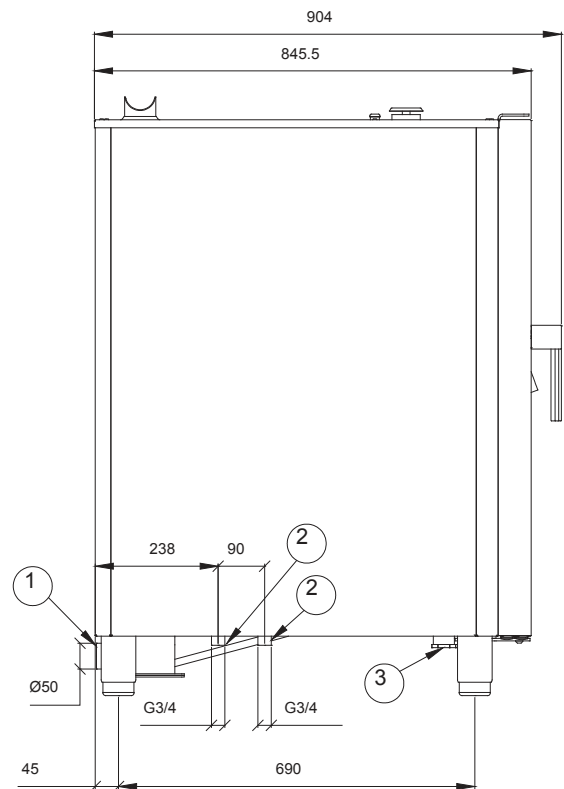
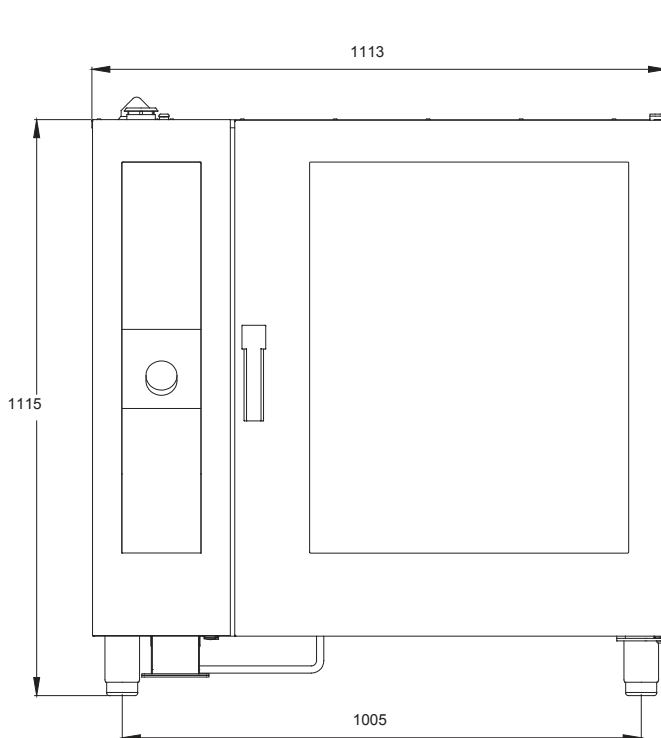

- ① DRAIN
- ② WATER INLET
- ③ POWER SUPPLY

# Technical data sheet

## Product benefits



### Combi convection steam oven STEAMBOX electric 10x GN 2/1 automatic cleaning boiler 400 V

Model

SAP Code

00008522

1

#### A symbiotic steam generation system

simultaneous use of direct injection and boiler, maintenance of 100% humidity, possibly its regulation the only Slim type combi oven on the market with a boiler

- preparation of different dishes and cooking styles in an environment precisely set for the food or dish

2

#### Touch screen display

simple intuitive control with unique pictograms, all in Czech the possibility of using preset programs or manual control

- help with cooking even for less skilled cooks, safe baking even in the absence of an operator; create your own recipes; easy to use

3

#### Weather system

patented device for measuring steam saturation in real time and in steam mode, the only one on the market

- precise information for the operator about the steam saturation in the cooking area

4

#### Steam tuner

a control element that enables setting the exact saturation of steam in the cooking chamber during the cooking process

- possibility of cooking different types of cuisine, from very moist steam for typical Czech dishes to low-saturated steam for e.g. French cuisine

5

#### Pass-through door

the door is also built into the back of the combi oven, while full control is retained from the side of the cook enables the distribution of the delivery area and the kitchen

- the chef can dispense the food through the convecto machine, the customer can see the preparation and maintenance of the food during dispensing

6

#### Adaptation for roasting chickens

the chamber of the convection oven is designed to collect baked fat, the machine is equipped with a container for collecting fat

- grease does not drain into the sewer, does not destroy the machine's waste system

7

#### A kit of two machines on top of each other

connection kit allowing two machines to be placed on top of each other connects the connections, inlets, wastes and ventilation of the lower combi oven

- allows the user to place two machines in smaller spaces to increase production; the chef can prepare two different dishes simultaneously

8

#### Premix burner

the only burner with a turbo pre-mixing gas with air on the market

the structure of the burner to V which prevents backfill and banging

This design saves 30 % of gas compared to conventional burners

- faster heat-up faster more comfortable operation

9

#### Automatic washing

integrated chamber washing system possibility to use liquid and tablet detergents option to use vinegar as a rinse agent the system simultaneously descales the micro-boiler

- the chamber of the conveyer is washed without the presence of the operator, for example overnight; the system decalcifies the micro-boiler without the need for service intervention; the chamber is maintained in a constant 1% hygienic quality

10

#### Self-supporting shower

drum winch integrated in the body of the kettle the shower is inaccessible when the door is closed

- allows food in the food processor to be rinsed out - if necessary to speed up cooling

11

#### Six-speed fan, reversible with automatic calculation of direction change

in cooperation with the symbiotic system, it ensures perfect steam distribution without losing its richness its operation is controlled by the program or manually

- allows the preparation of a variety of dishes from the most delicate to high temperature baking at the highest speed

# Technical data sheet

## Technical parameters



### Combi convection steam oven STEAMBOX electric 10x GN 2/1 automatic cleaning boiler 400 V

**Model**

**SAP Code**

00008522

**1. SAP Code:**

00008522

**2. Net Width [mm]:**

1120

**3. Net Depth [mm]:**

845

**4. Net Height [mm]:**

1115

**5. Net Weight [kg]:**

220.00

**6. Gross Width [mm]:**

1320

**7. Gross depth [mm]:**

1130

**8. Gross Height [mm]:**

1240

**9. Gross Weight [kg]:**

230.00

**10. Device type:**

Electric unit

**11. Power electric [kW]:**

28.300

**12. Loading:**

400 V / 3N - 50 Hz

**13. Material:**

AISI 304

**14. Exterior color of the device:**

Stainless steel

**15. Adjustable feet:**

Yes

**16. Humidity control:**

MeteoSystem - regulation based on direct measurement of humidity in the chamber (patented)

**17. Stacking availability:**

Yes

**18. Control type:**

Touchscreen + buttons

**19. Additional information:**

possibility of reverse door opening - handle on the right side (must be specified when ordering)

**20. Steam type:**

Symbiotic - boiler and injection combination (patent)

**21. Chimney for moisture extraction:**

Yes

**22. Delayed start:**

Yes

**23. Display size:**

9"

**24. Delta T heat preparation:**

Yes

**25. Automatic preheating:**

Yes

**26. Automatic cooling:**

Yes

# Technical data sheet

## Technical parameters



### Combi convection steam oven STEAMBOX electric 10x GN 2/1 automatic cleaning boiler 400 V

**Model**

**SAP Code**

00008522

**27. Cold smoke-dry function:**

Yes

**28. Unified finishing of meals EasyService:**

Yes

**29. Night cooking:**

Yes

**30. Washing system:**

Closed - efficient use of water and washing chemicals by repeated pumping

**31. Detergent type:**

Liquid washing detergent + liquid rinse aid/vinegar or washing tablets

**32. Multi level cooking:**

Drawer program - control of heat treatment for each dish separately

**33. Advanced moisture adjustment:**

Steamtuner - 5-stage system of setting steam saturation by controlled combination of production by boiler or injection

**34. Slow cooking:**

from 30 °C - the possibility of rising

**35. Fan stop:**

Immediate when the door is opened

**36. Lighting type:**

LED lighting in the doors, on both sides

**37. Cavity material and shape:**

AISI 304, with rounded corners for easy cleaning

**38. Reversible fan:**

Yes

**39. Sustance box:**

Yes

**40. Heating element material:**

Incoloy

**41. Probe:**

Yes

**42. Shower:**

Hand winder

**43. Distance between the layers [mm]:**

70

**44. Smoke-dry function:**

Yes

**45. Interior lighting:**

Yes

**46. Low temperature heat treatment:**

Yes

**47. Number of fans:**

1

**48. Number of fan speeds:**

6

**49. Number of programs:**

1000

**50. USB port:**

Yes, for uploading recipes and updating firmware

**51. Door constitution:**

Vented safety double glass, removable for easy cleaning

**52. Number of preset programs:**

100

# Technical data sheet

Technical parameters



Combi convection steam oven STEAMBOX electric 10x GN 2/1 automatic cleaning boiler 400 V

Model

SAP Code

00008522

**53. Number of recipe steps:**

9

**58. Number of GN / EN:**

10

**54. Minimum device temperature [°C]:**

30

**59. GN / EN size in device:**

GN 2/1

**55. Maximum device temperature [°C]:**

300

**60. GN device depth:**

65

**56. Device heating type:**

Combination of steam and hot air

**61. Food regeneration:**

Yes

**57. HACCP:**

Yes